

**Kaiser-Motoren**

Ein Unternehmen der PEJA-Gruppe



# CLEAN IN PLACE

EUROPEAN STAINLESS MOTORS





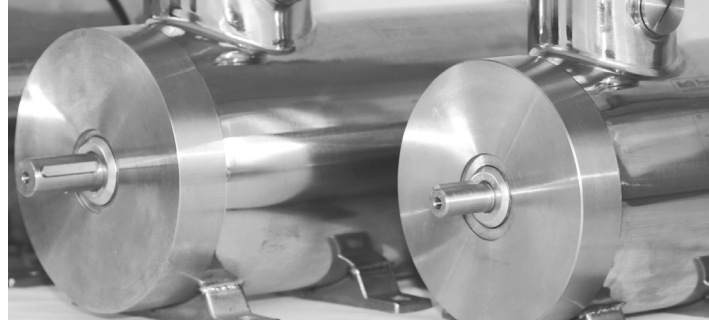

## BEATS CORROSION

All external metal components including motor shafts are manufactured in 304 series stainless steel. This gives excellent corrosion resistance. With a highly chemically resistant surface (**no paint to flake off**), they far out live standard painted motors in hygiene applications.

## WHERE HYGIENE COUNTS

Unlike standard motors the **Kaiser-Motoren** range has "clean lines" and no cooling fins. Designed with cleaning in mind; it has no paint to chip or flake off; no surface that will rust. Waste products can be washed away easily leaving no residue and the motor can be used with confidence in food processing areas. Even the rating plate is laser etched on the outer casing to reduce areas where bacteria can lurk.

## WASHDOWN TOLERANT

**EUROPEAN** manufactured and exceeding IP66 during external testing, the **Kaiser-Motoren** range is a proven design for CIP (Clean In Place) areas and washdown situations. A Viton double lip seal and a second GAMMA seal fitted on the shaft are examples of the attention to detail for protection against potential ingress during wash down.

## NO NEED TO BRUSH OR BAG, JUST WASH IT AWAY

STAINLESS



Before Cleaning



During Cleaning

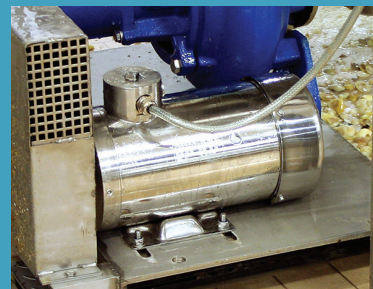

After Cleaning

STANDARD



Before Cleaning



During Cleaning



After Cleaning









## CLEAN FEATURES

### RATED FOR...

#### "STATIC" FREQUENCY CONTROLLERS/ VARIABLE SPEED DRIVE OR INVERTER US

The whole Kaiser-Motoren range is suitable for inverter drive use and has phase barriers and PTC thermistors fitted as standard. On request PTO (Klixon style) bi-metallic thermostats can be fitted as an alternative to protect against over-temperature.

### ETCHED NAMEPLATES

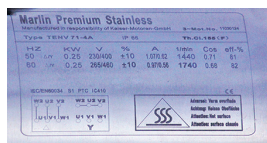

The nameplates and fixings on standard motors are prime areas for waste and dirt entrapment.

They corrode, get damaged and even detach. The Kaiser-Motoren Range has the technical data etched directly onto the motor body, thus eliminating these hygiene and safety risks.

### IP66 SEALING

Defined by IEC 60034-5, the code consists of 'IP' Ingress Protection rating: two digits, the higher the numbers; the higher the protection. The first digit relates to the ingress of dust or solid particles, but it is the second digit which is more important for this product range, as it relates to the protection level against water projected in powerful jets from any direction. This makes the product ideal for critical washdown applications.



### TEFC AND TENV

**Totally Enclosed Fan Cooled** motors rely on air being pulled from the non-drive end of the motor through a fan; this is then blown over the motor body to help dissipate the generated heat.

**Totally Enclosed Non Ventilated** motors work on the basis of more active material and optimised efficiencies, reducing the heat generated through losses thus negating the need for a fan. The TENV types are standard up to and including 0.75Kw and due to their design have cleaner lines and fewer areas for entrapment of dirt or waste product.

### TROPICALISED INTERNAL COMPONENTS

Corrosion-resistant rotors and advanced winding varnishing techniques dramatically increase the motor's reliability and expected lifetime.

### ROUND TERMINAL BOX AS STANDARD

The round smooth terminal box, which is machined and welded directly onto the frame of the motor, has fewer places to trap water or dirt. It also benefits from smooth hygienic gland-seat extension, proving again the attention to detail from a hygienic perspective. This will be seen as another important factor for factory inspectors/auditors.





## 3000 RPM (2 POLE)

Type	Rated output	Rated speed	Efficiency	Voltage connection	Rated current at voltage	100% Full Load Torque	Starting current ratio	Breakaway Torque	Pull out Torque	B3* Weight	B14* Weight	B5* Weight	Cooling
IEC FRAME	kW	min <sup>-1</sup>	% FL	▲/Y		Mn Nm	I <sub>A</sub> /I <sub>N</sub>	M <sub>A</sub> /M <sub>N</sub>	M <sub>K</sub> /M <sub>N</sub>	kg	kg	kg	
63-2A	0.18	2800	75.0	230/400	0.78/0.45	0.62	6.8	3.1	4.1	7.6	7.1	9.9	TENV
63-2B	0.25	2830	76.8	230/400	1.0/0.58	0.84	7.0	3.0	4.0	9.5	9.0	11.8	TENV
71-2A	0.37	2830	80.4	230/400	1.39/0.8	1.26	8.0	3.5	4.4	12.6	12.3	12.7	TENV
71-2B	0.55	2880	82.0	230/400	1.92/1.11	1.85	7.3	3.4	4.3	14.5	14.1	14.6	TENV
80-2A	0.75	2885	IE2-81.5	230/400	2.56/1.48	2.49	8.5	3.9	4.6	19.5	18.9	20.3	TENV
80-2B	1.1	2900	IE2-82.0	230/400	3.72/2.15	3.67	8.0	3.1	4.0	25.1	24.5	25.9	TEFC
90S-2	1.5	2855	IE2-82.5	230/400	5.45/3.15	5.02	8.0	2.7	3.4	21.0	20.0	21.5	TEFC
90L-2	2.2	2800	IE2-83.4	230/400	7.70/4.45	7.54	8.5	3.1	3.8	25.4	24.4	25.9	TEFC
100L-2	3.0	2915	IE2-84.6	230/400	9.60/5.5	9.86	7.8	2.4	3.2	38.6	38.0	40.0	TEFC
112M-2	4.0	2900	IE2-86	400/690	7.70/4.45	13.25	7.2	2.6	3.4	46.4	44.8	46.1	TEFC
132SB-2**	7.5	2925	IE2-88.1	400/690	13.60/7.85	9.86	8.0	2.5	3.5	62.6	61.0	64.0	TEFC

## 1500 RPM (4 POLE)

Type	Rated output	Rated speed	Efficiency	Voltage connection	Rated current at voltage	100% Full Load Torque	Starting current ratio	Breakaway Torque	Pull out Torque	B3* Weight	B14* Weight	B5* Weight	Cooling
IEC Baugröße	kW	min <sup>-1</sup>	% FL	▲/Y		Mn Nm	I <sub>A</sub> /I <sub>N</sub>	M <sub>A</sub> /M <sub>N</sub>	M <sub>K</sub> /M <sub>N</sub>	kg	kg	kg	
63-4	0.18	1385	71.0	230/400	0.95/0.55	1.25	3,8	2,7	2,5	13.0	8.8	9.9	TENV
71-4A	0.25	1440	81.0	230/400	1.07/0.62	1.67	5,1	2,3	2,8	14.4	12.7	13.2	TENV
71-4B	0.37	1440	80.0	230/400	1.8/1.04	2.48	4,5	2,4	2,9	18.5	14.0	14.5	TENV
80-4A	0.55	1440	82.0	230/400	2.35/1.35	3.68	5,7	3,3	3,1	21.8	17.6	19.8	TENV
80-4B	0.75	1455	84.0	230/400	3.22/1.86	4.91	7,5	3,9	4,2	21.0	21.0	22.5	TENV
90S-4	1.1	1440	83.0	230/400	4.3/2.5	7.32	6,2	2,4	3,2	26.8	20.0	21.5	TEFC
90L-4	1.5	1440	83.0	230/400	6.1/3.5	9.94	6,2	2,6	2,7	32.9	25.8	27.3	TEFC
100LA-4	2.2	1440	84.6	230/400	7.83/4.52	14.64	6,8	2,6	3,1	40.4	32.1	39.6	TEFC
100LB-4	3.0	1450	85.5	230/400	11.1/6.4	19.80	7,5	2,7	3,2	52.6	39.7	47.1	TEFC
112M-4	4.0	1455	87.0	400/690	7.8/4.5	26.29	5,7	1,7	2,6	66.6	51.0	52.3	TEFC
132M-4**	7.5	1450	88.7	400/690	15.20/8.8	49.70	5,1	1,7	2,5	75.6	73.8	76.8	TEFC

\* Motor weights are un boxed, please add for packaging.

\*\* Full data sheet available upon request, including 60Hz data. (All motors able to run at 60Hz)

6 Pole motor data is available upon request



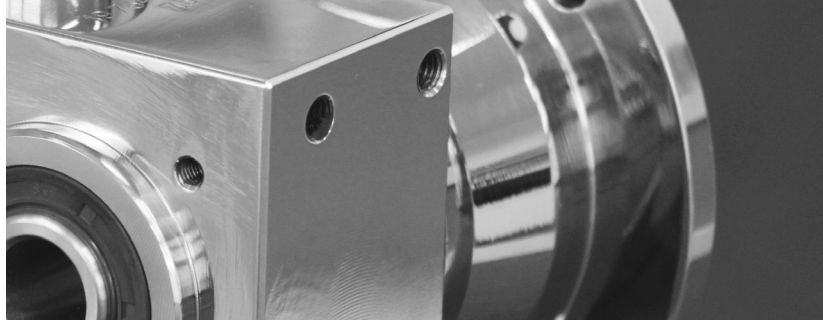

## CLEAN CHOICES

Further options from production or as stock modifications include:

-  Alternative terminal box positions for foot mounted motors
- Pharmaceutical grade polishing exceeding 0.5 microns
- Heaters - Used to reduce condensation and keep moisture out. They also help keep windings and bearings within normal operating temperature in low ambient conditions
- Application specific drain plugs can be fitted when needed on request as a proven way of removing condensation from inside the motor



## CLEAN GEARBOXES

Smooth-bodied stainless steel gearboxes are available. Their linear design makes them ideal for multi-stacking. This enables very low output speeds and high torques to be achieved which are not commonly available.



## CLEAN CUSTOMISATION

**SPECIAL CONSTRUCTION TENV AND TEFC** - outside of standard powers.

**SPECIAL SHAFTS AND FLANGES INCLUDING SEW DRIVE END SOLUTION**

The standard IEC flange configurations are commonly required for the majority of pump, fan and gearbox applications. However, we are also able to produce special drive end flange and shaft solutions for customised machinery. One example seen in the photo is the solution for SEW Eurodrive who are a major supplier to the food and beverage industry. We can supply motors with the special shaft and flange required for this range of gearboxes to enable direct replacements without the need for adaptors.

**WATER-COOLED** stainless steel motors for extreme high ambient environments and where more compact and high powers are necessary - more cooling equals more power.





## OPTIONAL FEATURES



### SPECIAL ELECTRICAL DESIGN

Windings can be spot-wound for special voltage and frequencies outside of European standards, thermal insulation to Class F, and/or have a certified insulation system fitted such as UL/CSA standards.

**ATEX** - Zone 22 available on request.

**ADDITIONAL ETCHING** - Company logos, web addresses, order references and warnings can be etched directly onto the motor body in addition to the existing nameplate information.

### OPTIONAL ENHANCED SEALING ARRANGEMENTS FOR EXTREME APPLICATIONS

Experience has proven that enhanced sealing techniques can dramatically extend the motor's lifetime in extreme applications and mounting conditions, predominantly vertical shaft up. Magnetic sealing systems with precise labyrinth clearances are available for such arduous applications. These compact, precision lapped, face contact, mechanical seals give bi-directional protection where 100% positive seal protection is required with or without shaft rotation. This is very important to prevent pooling issues in shaft up applications when stationary or cooling back. They create zero shaft wear, prevent lubrication loss, eliminate contamination (solids, liquids and steam), have self-aligning faces and increase the equipment MTBF (Mean Time Between Failure).

Encapsulated compound completely moulding and protecting the connections inside the terminal box with IP66 glands and bespoke flying leads to customers required specifications.

Optional increased protection to IP69K for TENV motors. In the IEC 60529 rating system, IP6X refers to the product's ability to resist ingress of dust whereas the IPX9K refers to the product's ability to resist ingress of high temperature (steam)/high pressure water.







## CLEAN DIMENSIONS

### FRAME SIZE 63 TO 80 – B3 FOOT MOUNTED – TENV

Frame type	Poles#	A	B	C	D	E	F	G	H	K	K1	U	ØW	AB	AC	AD	DB	ED	GA	GD	LE	WC	LENGTH		
																							2 pole L	4 pole L	6 pole L
MSS63-2A	2	100	80	40	11	23	4	8.5	63	10	7	2xM20	76	125	114	114	M4	19	12.5	4	23	79	211	x	x
MSS63-#B	2, 4	100	80	40	11	23	4	8.5	63	10	7	2xM20	76	125	114	114	M4	19	12.5	4	23	79	236	236	x
MSS71-#A	2,4,6	112	90	45	14	30	5	11	71	10	7	2xM20	76	140	134	124	M5	25	16	5	30	84	243	243	253
MSS71-#B	2,4,6	112	90	45	14	30	5	11	71	10	7	2xM20	76	140	134	124	M5	25	16	5	30	84	273	254	273
MSS80-#A	2,4,6	125	100	50	19	40	6	15.5	80	14	10	2xM25	89	150	144	130	M6	34	21.5	6	40	90	313	307	307
MSS80-#B	2,4,6	125	100	50	19	40	6	15.5	80	14	10	2xM25	89	150	144	130	M6	34	21.5	6	40	90	337	347	367

### FRAME SIZE 80 TO 132 – B3 FOOT MOUNTED – TEFC

Frame type	Poles#	A	B	C	D	E	F	G	H	K	K1	U	ØW	AB	AC	AD	DB	ED	GA	GD	LE	WC	LENGTH		
																							2 pole L	4 pole L	6 pole L
MSS80B-2B	2	125	100	50	19	40	6	16	80	10	14	2xM25	89	150	156	132	M6	34	22	6	40	93	363	x	x
MSS90S	2,4,6	140	100	56	24	50	8	20	90	9	9	2xM25	89	164	176	145	M8	46	27	7	50	95	327.5	311.5	347.5
MSS90L	2,4,6	140	100	56	24	50	8	20	90	9	9	2xM25	89	164	176	145	M8	46	27	7	50	95	351.5	327.5	377.5
MSS100LA#	2,4,6	160	140	63	28	60	8	24	100	16	12	2xM25	114	192	201	160	M10	55	31	7	60	123	402.5	417.5	442.5
MSS100LB#	4	160	140	63	28	60	8	24	100	16	12	2xM25	114	192	201	160	M10	55	31	7	60	123	x	462.5	x
MSS112#	2,4,6	190	140	70	28	60	8	24	112	16	12	2xM25	114	220	218	171	M10	55	31	7	60	128	437.5	437.5	tba
MSS132#	2,4,6	216	178	89	38	80	10	33	132	16	12	2xM25	114	246	258	192	M12	70	41	8	80	147	448.5	478.5	478.5

### FRAME SIZE 63 TO 80 – B14/B34 FACE MOUNTED – TENV

Frame type	Poles	Face	D	E/LE	F	G	M	N	P	S	T	ØW	AC	AD	DB	WC	2 pole L	4 pole L	6 pole L
MSS63-2A	2	FT75	11	23	4	8.5	75	60	90	M5	2.5	76	114	111	M4	79	211	x	x
MSS63-#B	2, 4	FT75	11	23	4	8.5	75	60	90	M5	2.5	76	114	111	M4	79	236	236	x
MSS71-#A	2,4,6	FT85	14	30	5	11	85	70	105	M6	2.5	76	134	124	M5	84	243	243	253
MSS71-#B	2,4,6	FT85	14	30	5	11	85	70	105	M6	2.5	76	134	124	M5	84	273	254	273
MSS80-#A	2,4,6	FT100	19	40	6	15.5	100	80	120	M6	3	89	144	130	M6	90	313	307	307
MSS80-#B	2,4,6	FT100	19	40	6	15.5	100	80	120	M6	3	89	144	130	M6	90	337	347	367

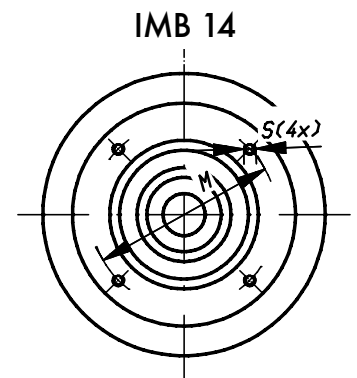

### FRAME SIZE 80 TO 132 – B14/B34 FACE MOUNTED – TEFC

Frame type	Poles	Face	D	E/LE	F	G	M	N	P	S	T	ØW	AC	AD	DB	WC	2 pole L	4 pole L	6 pole L
MSS80B-2B	2	FT100	19	40	6	16	100	80	120	M6	3	89	156	132	M6	93	363	x	x
MSS90S	2,4,6	FT115	24	50	8	20	115	95	140	M8	3	89	176	145	M8	95	327.5	311.5	347.5
MSS90L	2,4,6	FT115	24	50	8	20	115	95	140	M8	3	89	176	145	M8	95	351.5	327.5	377.5
MSS100LA	2,4,6	FT130	28	60	8	24	130	110	160	M8	3.5	114	201	160	M10	123	402.5	417.5	442.5
MSS100LB	4	FT130	28	60	8	24	130	110	160	M8	3.5	114	201	160	M10	123	x	462.5	x
MSS112	2,4,6	FT130	28	60	8	24	130	110	160	M8	3.5	114	218	171	M10	128	437.5	437.5	tba
MSS132#	2,4,6	FT165	38	80	10	33	165	130	200	M10	3.5	114	258	192	M12	147	448.5	478.5	478.5

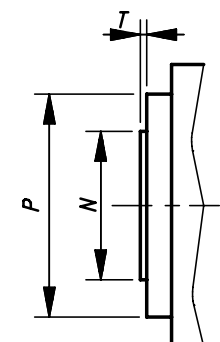

\* All dimensions are in mm's

\* # denotes Poles



**IMB 35**

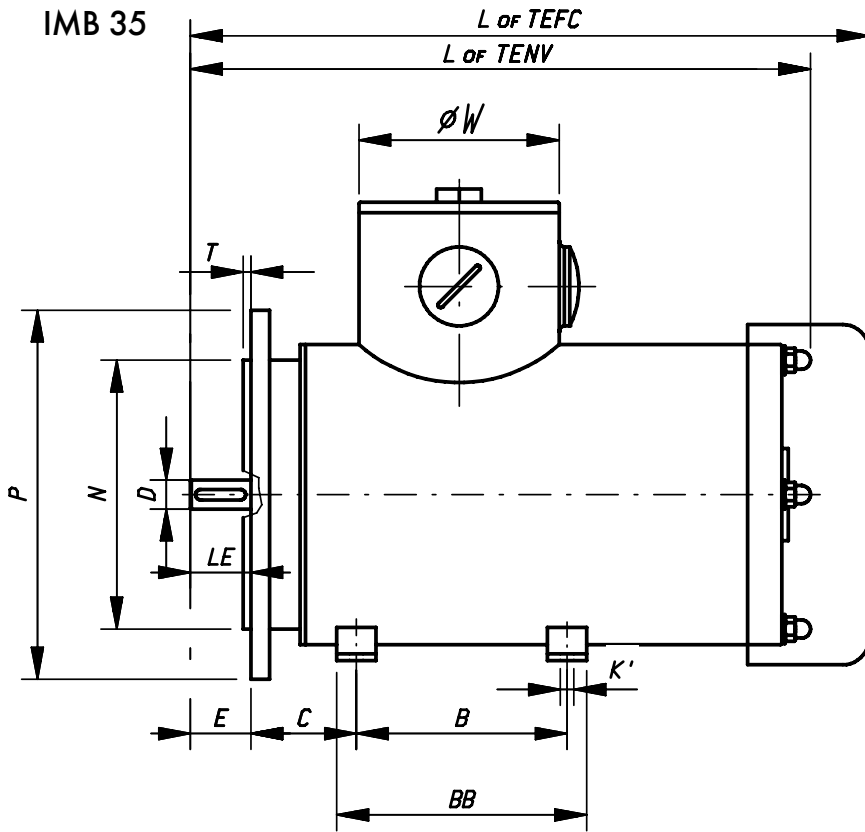

Individual Motor drawings available on request

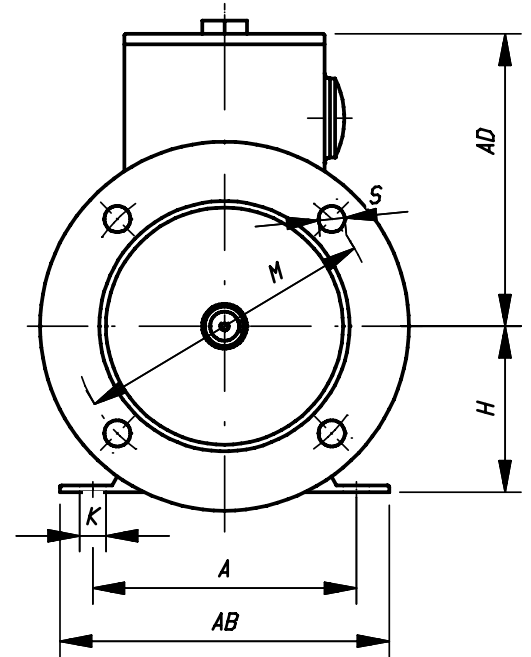

**FRAME SIZE 63 TO 80 – B5/B35 FLANGE MOUNTED – TENV**

Frame type	Flange	Poles	D	E/LE	F	G	M(LK)	N	P	S	T	ØW	AC	AD	DB	WC	2 pole L	4 pole L	6 pole L
MSS63-2A	FT115	2	11	23	4	8.5	115	60	90	M5	2.5	76	114	111	M4	79	211	x	x
MSS63-#B	FT115	2,4	11	23	4	8.5	115	60	90	M5	2.5	76	114	111	M4	79	236	236	x
MSS71-#A	FT130	2,4,6	14	30	5	11	130	70	105	M6	2.5	76	134	124	M5	84	243	243	253
MSS71-#B	FT130	2,4,6	14	30	5	11	130	70	105	M6	2.5	76	134	124	M5	84	273	254	273
MSS80-#A	FT165	2,4,6	19	40	6	15.5	165	80	120	M6	3	89	144	130	M6	90	313	307	307
MSS80-#B	FT165	2,4,6	19	40	6	15.5	165	80	120	M6	3	89	144	130	M6	90	337	347	367

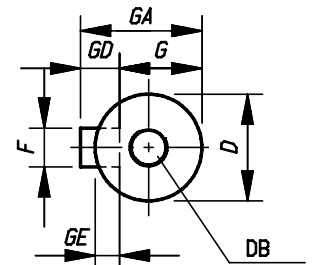

**SHAFT**

**FRAME SIZE 80 TO 132 – B5/B35 FLANGE MOUNTED – TEFC**

Frame type	Flange	Poles	D	E/LE	F	G	M(LK)	N	P	S	T	ØW	AC	AD	DB	WC	2 pole L	4 pole L	6 pole L
MSS80B	FT165	2	19	40	6	16	100	80	200	M6	3	89	156	132	M6	93	363	x	x
MSS90S	FT165	2,4,6	24	50	8	20	115	95	200	M8	3	89	176	176	M8	99	327.5	311.5	347.5
MSS90L	FT165	2,4,6	24	50	8	20	115	95	200	M8	3	89	176	176	M8	99	351.5	327.5	377.5
MSS100LA	FT215	2,4,6	28	60	8	24	130	110	250	M8	3.5	114	201	202	M10	123	402.5	417.5	442.5
MSS100LB	FT215	4	28	60	8	24	130	110	250	M8	3.5	114	201	202	M10	123	x	462.5	x
MSS112	FT215	2,4,6	28	60	8	24	130	110	250	M8	3.5	114	218	231	M10	128	437.5	437.5	tba
MSS132#	FT265	2,4,6	38	80	10	33	165	130	300	M10	3.5	114	258	260	M12	147	448.5	478.5	478.5

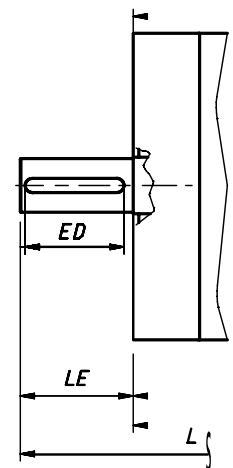

**IMB 3**





## CLEAN REGULATIONS



The European standard **EN 1672-2** which defines hygiene requirements for food production machinery, specifies three zones for the industry:

- 1 FOOD ZONE**
- 2 SPLASH ZONE**
- 3 NON-FOOD ZONE**

The non-food zone covers components which do not come in contact with foodstuffs. It is nonetheless still mandatory to use corrosion-resistant materials in the non-food zone.

### CLEAN IN PLACE

When food, beverage or pharmaceutical production plants are washed down, the motors are subjected to high pressure jets of sometimes high-temperature water, or aggressive cleaning agents. Dependent upon the severity of this washdown, many consequences can occur including failure of the motor on start up through ingress of water, corrosion of exterior or internal parts if using standard alloy or cast iron material and potential for paint flaking and contaminating the final product itself.



## DESIGNED WITH STANDARDS IN MIND

### **DIN EN ISO 14159**

Safety of machinery. Hygiene requirements for the design of machinery. Installations represent potential hygiene risks to food which could endanger consumers. The Standard specifies measures to avoid risk which must be taken by manufacturers

### **DIN EN 1672-2:2005+A1:2009**

Food processing machinery. Basic concepts. Hygiene requirements. It also contains general notes on the special requirements relating to preferred equipment materials.

### **ISO 11664-2:2007 (CIE S 014-2/E:2006)**

Standard for cleaning and disinfection

### **ISO 8086:2004 (IDF 121:2004)**

Dairy plant. Hygiene conditions. General guidance on inspection.





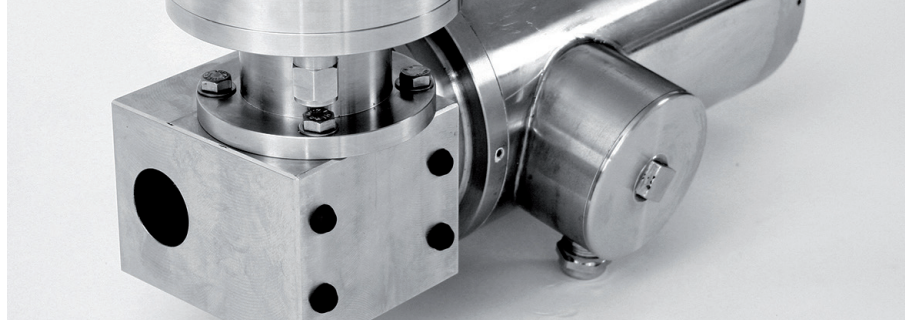

## FRAME SIZE

## DRIVE END

## NON-DRIVE END

MSS63	6202	6202
MSS71	6203	6203
MSS80	6204	6204
MSS90	6205	6205
MSS100	6306	6306
MSS112	6306	6306
MSS132	6308	6208



## BEARINGS

The bearings used in the Kaiser-Motoren range have special synthetic high-temperature lubricating grease with a wide operating range  $-40^{\circ}\text{C}$  to  $180^{\circ}\text{C}$ , and an excellent Drop point, DIN ISO 2176  $\geq 250^{\circ}\text{C}$ . They have excellent ageing and oxidation stability. Mechanically they are to C3 clearance and are fixed at the drive end to reduce axial shaft movement making the range suitable for mixers and close coupled pumps.

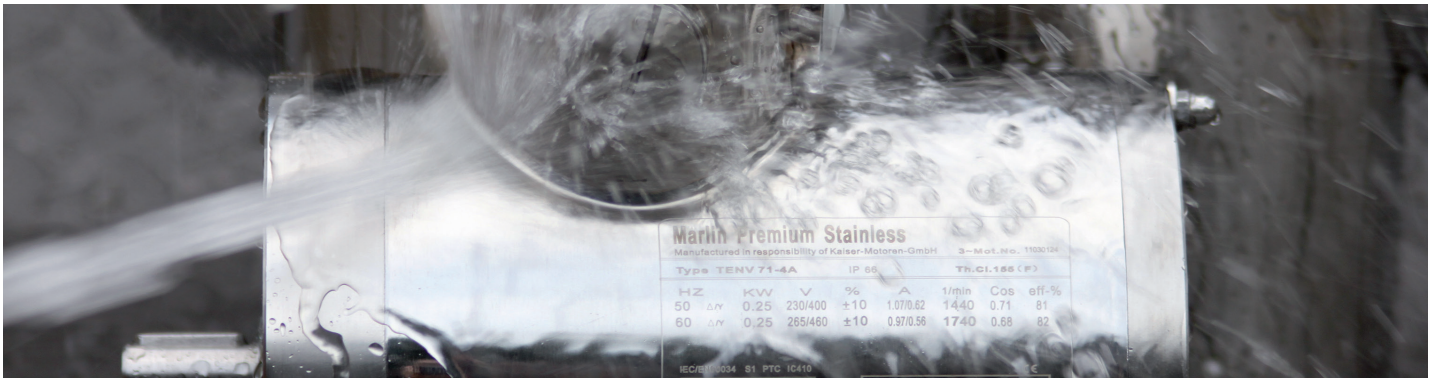

## SAFETY STANDARDS

Our motors comply with the requirements of the International Standard IEC 60034 for rotating electrical machines as well as the following European Directives:

Low Voltage Directive (LV) 2014/35/EU, Electromagnetic Compatibility Directive (EMC) 2014/30/EU and RoHS Directive 2011/65/EG on the restriction of hazardous substances in electrical and electronic equipment.

All products comply with the requirements of the Machines Directive (MD) 2006/42/EC. In accordance with this Directive, induction motors are components intended solely for integration into other machines. Commissioning is forbidden until conformity of the end-product with this Directive is proven.



The CE marking was applied for the first time in 1995.

When operating the motor, the observance of the Regulation EN 60204-1 and safety instructions indicated in our Operating Instructions must be complied with.

Motors can be supplied with other international Standards on request:



Motors can be supplied with insulation approved by UL Underwriters Laboratories Inc.

All technical data, outputs, dimensions and weights stated in this catalogue are subject to change without prior notice. The illustrations are not binding.

Manufactured to a **Quality Management System ISO9001:2008**





# Kaiser-Motoren

Ein Unternehmen der PEJA-Gruppe



**Kaiser-Motoren GmbH**  
Ein Unternehmen der PEJA Gruppe  
Kieler Straße 558  
24536 Neumünster, Germany

---

## ZENTRALE

**TEL** +49 (0) 4321 - 99 77 - 0  
**FAX** +49 (0) 4321 - 99 77 - 40  
**MAIL** [info@kaiser-motoren.de](mailto:info@kaiser-motoren.de)  
**WEB** [www.kaiser-motoren.de](http://www.kaiser-motoren.de)

---

## VERTRIEB/SALES

**TEL** +49 (0) 4321 - 99 77 - 33/34  
**FAX** +49 (0) 4321 - 99 77 - 40  
**MAIL** [verkauf@kaiser-motoren.de](mailto:verkauf@kaiser-motoren.de)

---

## EINKAUF/PURCHASE

**TEL** +49 (0) 4321 - 99 77 - 19  
**FAX** +49 (0) 4321 - 99 77 - 40

---

## BUCHHALTUNG/ACCOUNTANCE

**TEL** +49 (0) 4321 - 99 77 - 18  
**FAX** +49 (0) 4321 - 99 77 - 40  
**MAIL** [buchhaltung@kaiser-motoren.de](mailto:buchhaltung@kaiser-motoren.de)

